

16/07/2024



NX¹

USER MANUAL

Version 3.0



NEXT

Model

Vehicle Identification Number

Paint Reference

First Registration

Number Plate

After sales service contact person

Mr/Mrs.

Phone Number

Dealership's Address

IMPORTANT



Warning: Rules and precautionary measures aimed at protecting the driver and other individuals against deadly hazards."



Attention: Precautionary measures and special notices aimed at preventing vehicle deterioration. Failure to obey these instructions may result in loss of warranty rights.



Notice: Precautionary measures and special warnings aimed at preventing vehicle deterioration. Failure to obey these instructions may result in the loss of warranty rights.



Welcome to NEXT!

Welcome to NEXT!

Firstly, thank you very much for choosing our electric **scooter NX**¹.

This manual covers the basic performance, the adjustment methods, the instructions to ride safely and the electric vehicle maintenance information.

For your own safety and the most satisfying riding experience, read the content of this manual carefully before riding your electric scooter. Your safety when riding your electric scooter not only depends on your personal state of alertness, and your riding skills, it also depends on the mechanical performance of the electric vehicle.

It is essential that you check and maintain the electric vehicle before using it. This electric vehicle will be your ideal transportation tool as long as you check it over before using it, master the riding techniques and obey the traffic rules.

Due to the constant improvement processes carried out on this product, the relevant data and the structure of this manual might be modified without prior notice.

Reminder:

Do not use the electric vehicle without carefully reading the instructions and understanding its functions. Do not lend it to anyone who does not know how to use or ride this vehicle.

<i>1. Summary of models</i>	1
<i>2. Equipment and accessories</i>	2
<i>3. Vehicle blueprints</i>	3
<i>4. View of the handlebars and button panels</i>	6
<i>5. Display</i>	9
<i>6. Instructions of use</i>	11
<i>7. Battery Uses and Recommendations</i>	12
<i>8. Vehicle maintenance</i>	18
<i>9. Warranty</i>	21
<i>10. Return Policy</i>	23
<i>11. Technical specifications</i>	25

FEEL THE FUTURE

UP TO 100KM

BATTERY RANGE

45KM/H

MAX. SPEED

1.7 kW

PEAK POWER





NX¹



Pure White | Black Matte | Space Gray | Electric blue | Yellow Minion

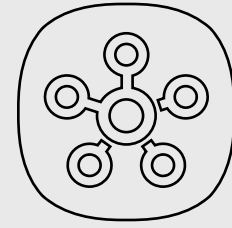

Equipment/ Accessories

No.	Name	Unit	Qty.	Comments
1	Electric vehicle	Unit	1	
2	Set of keys- Remote control	Set	4	
3	Rear- view- mirrors	Set	2	
4	User manual	Unit	1	
5	Charger	Unit	1	
6	Battery	Couple	2	

 Once the product purchased has been used it is assumed that the user accepts that the configuration of the product is complete and intact, and therefore other free configuration requests from customers shall not be accepted.

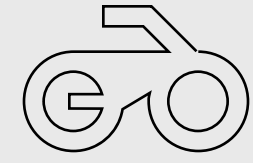

Blueprints of the vehicle

Main profile view

No.	Part no.
1	Display
2	Front indicator
3	Front headlight
4	Front sidelight
5	Horn
6	Battery
7	Motor
8	DC Converter
9	Brake calipers and hoses
10	Brake light
11	Rear indicator
12	Number Plate light
13	USB port

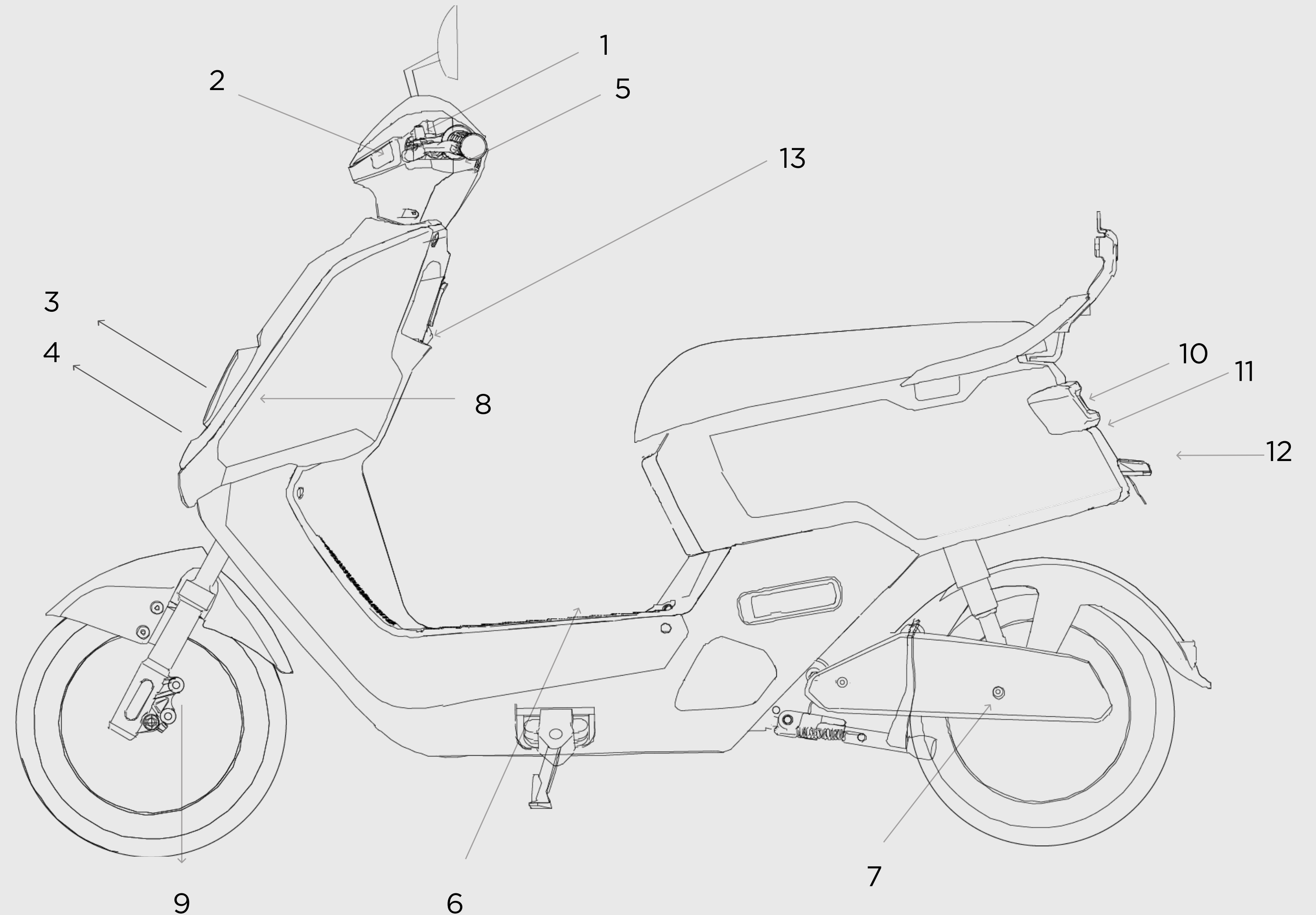

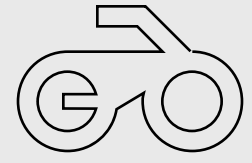

Blueprints of the vehicle

Main rear and front view

No.	Part No.
1	Brake light
2	Rear indicator
3	Rear reflector
4	N° plate light
5	Front headlight
6	Sidelight
7	Front Indicators

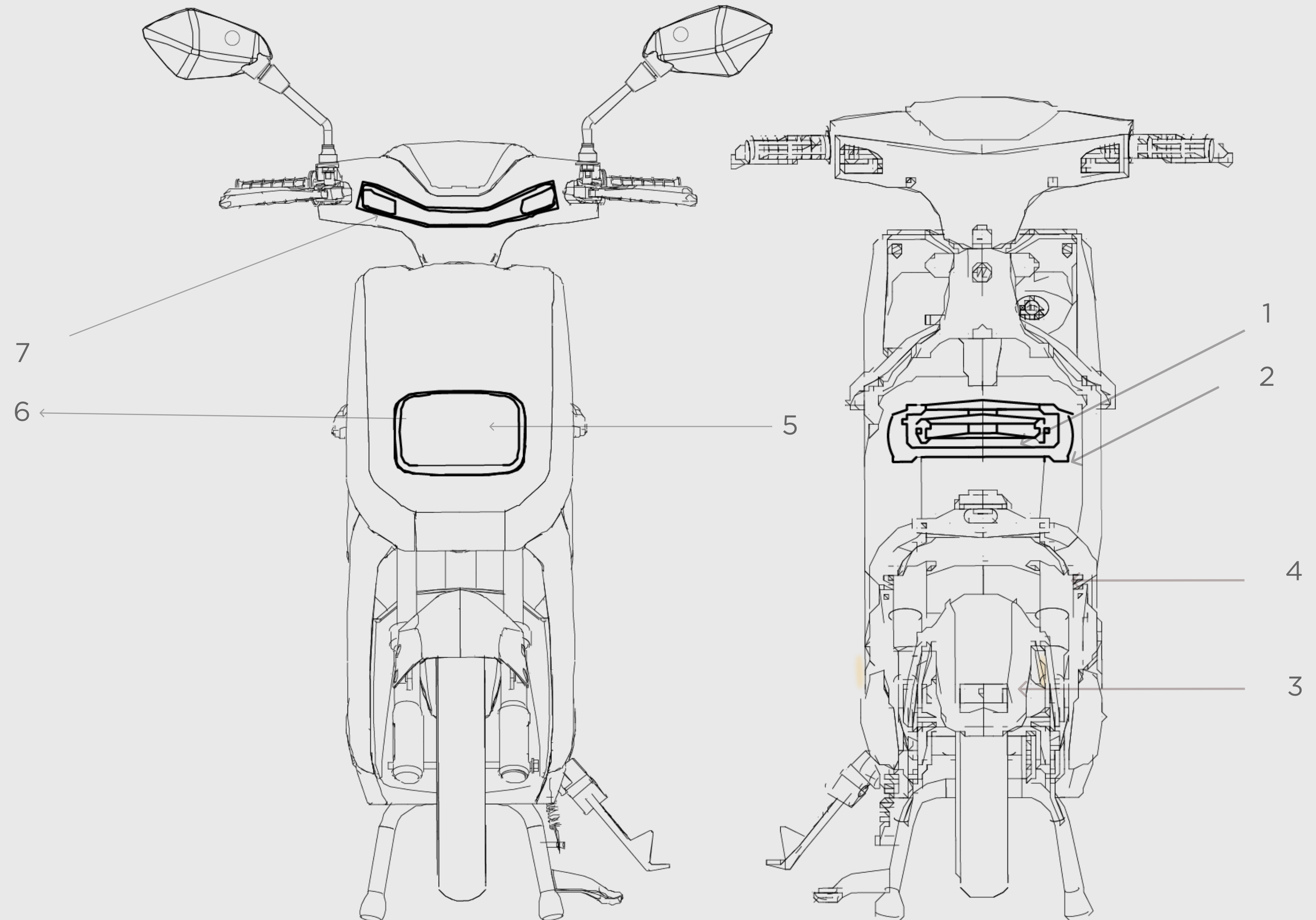

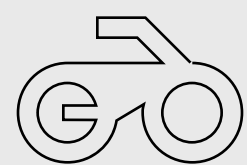

Blueprints of the vehicle

Size of the vehicle

1670 x 690 x 1060 mm

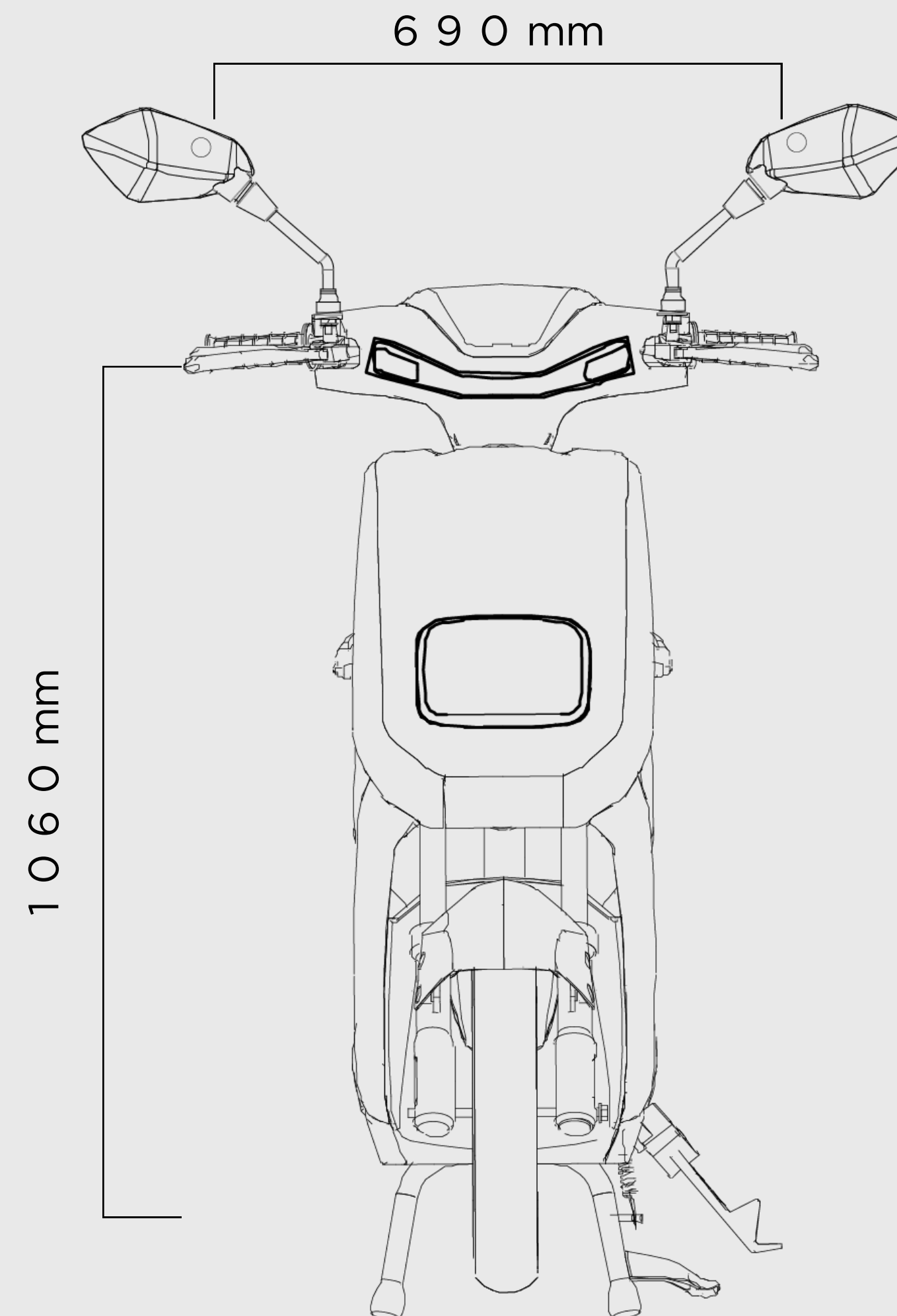
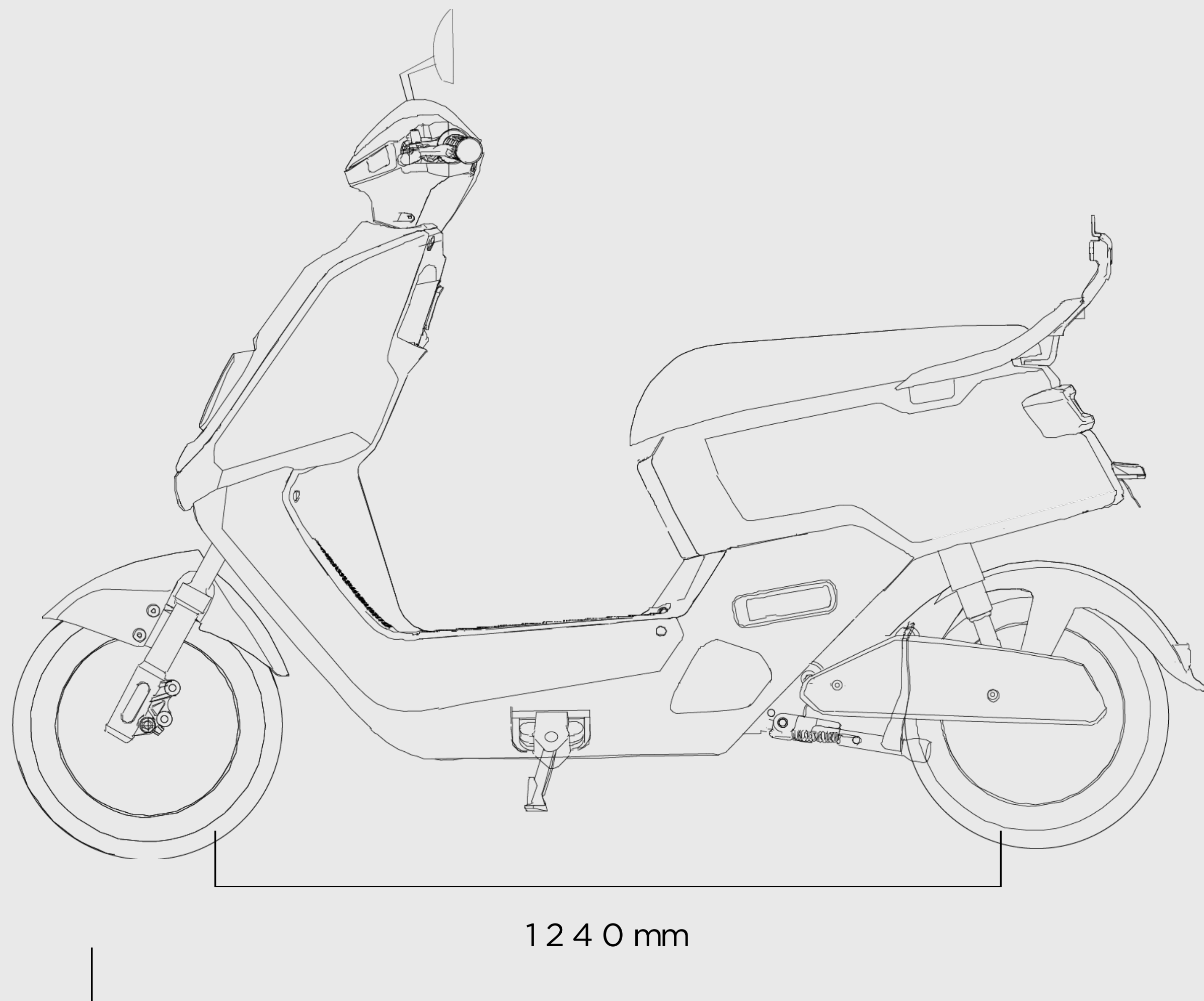



Blueprints of the vehicle

Handlebar View

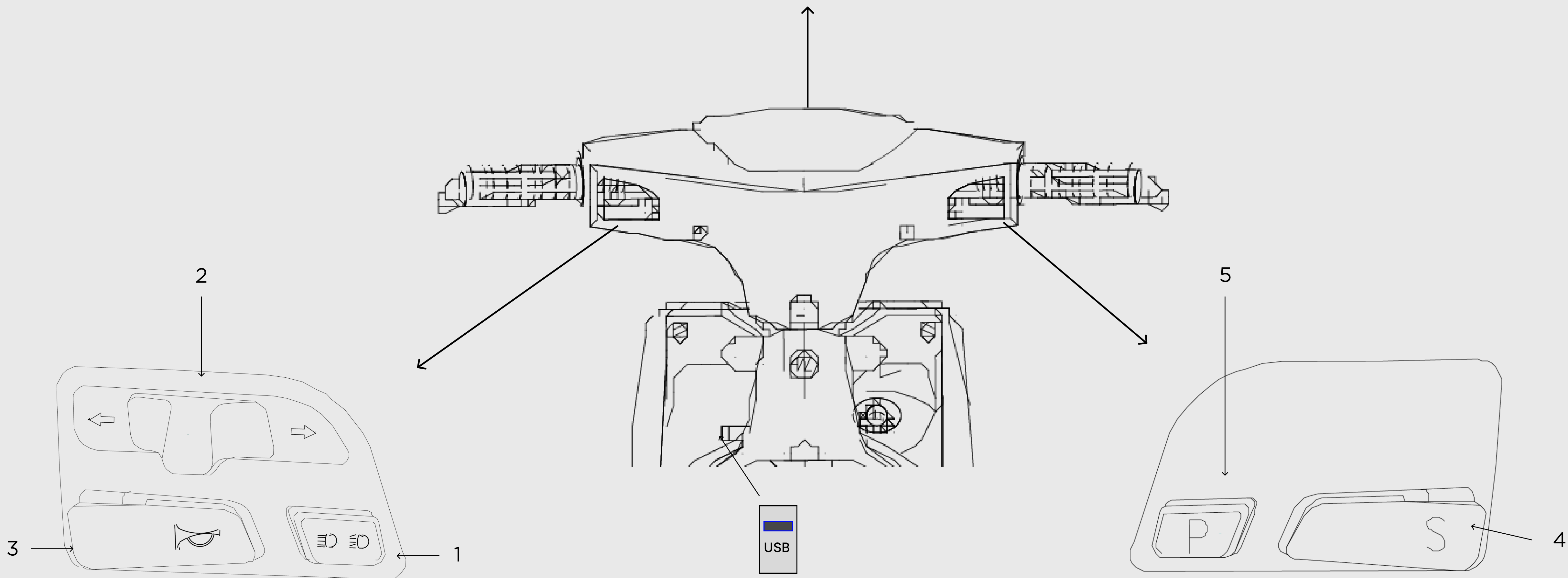



Handlebar View

Handlebar buttons

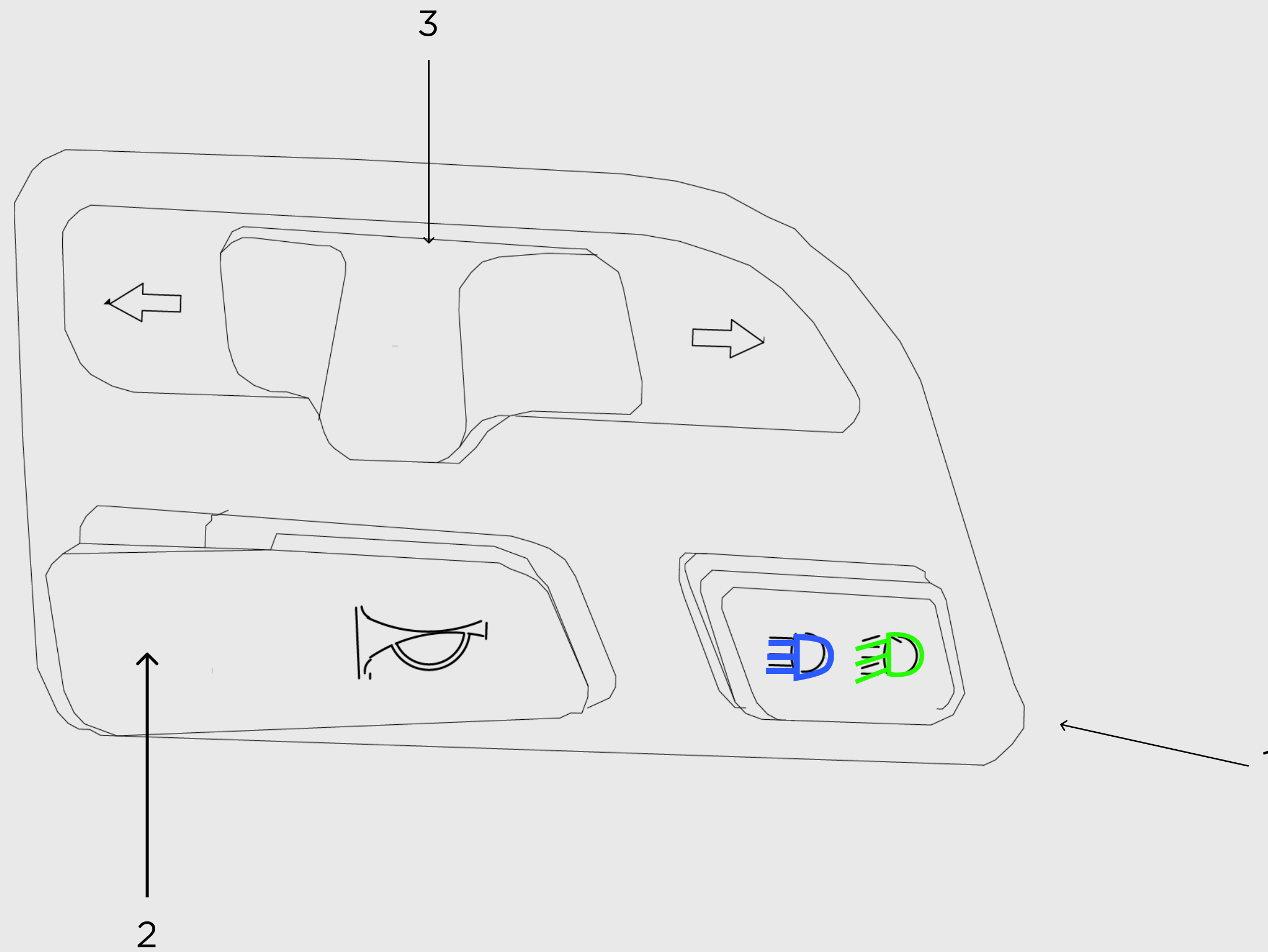

No.	Part No.
1	Lights Switch
2	Horn
3	Blinkers



Handlebar View

Handlebar buttons

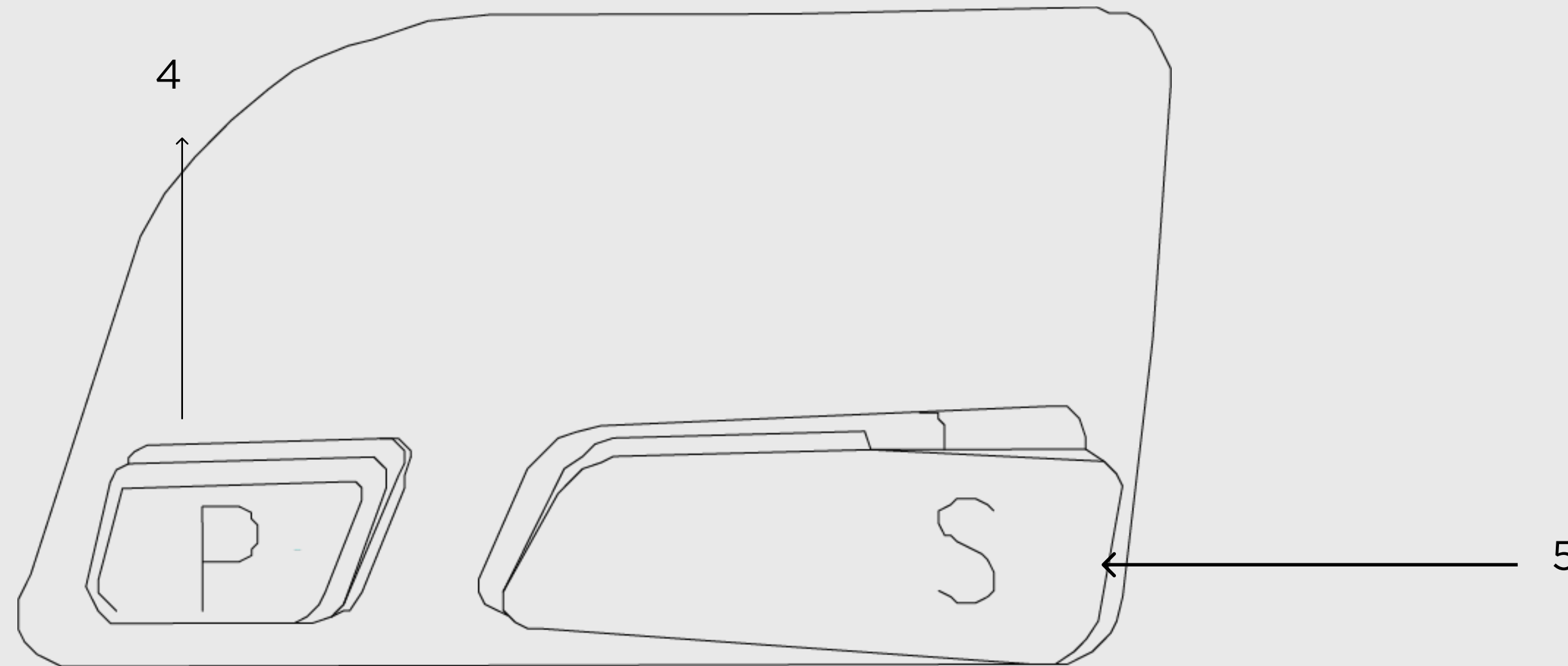

No.	Part No.
4	PArkingmode
5	Riding Mode



The riding mode has three modes:
P- Power/ S-Speed and E- Eco

The change is optional according to the preferences of the user. The riding mode will appear on the [DISPLAY page 9](#).

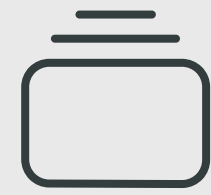

Display/ Speedometer

Riding Mode

⤴ Before using the vehicle bear in mind that to activate the riding modes, the N mode (Stop) has to be disabled. This is done by releasing the brake lever

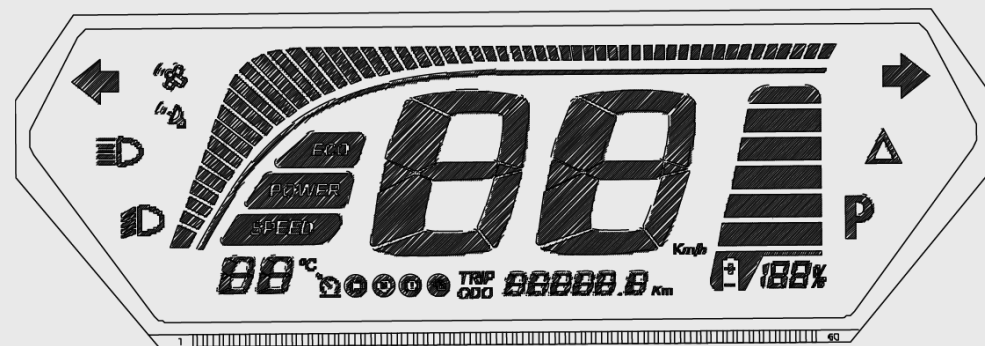

P Mode (Parking)

In P mode the electric scooter will remain stationary.

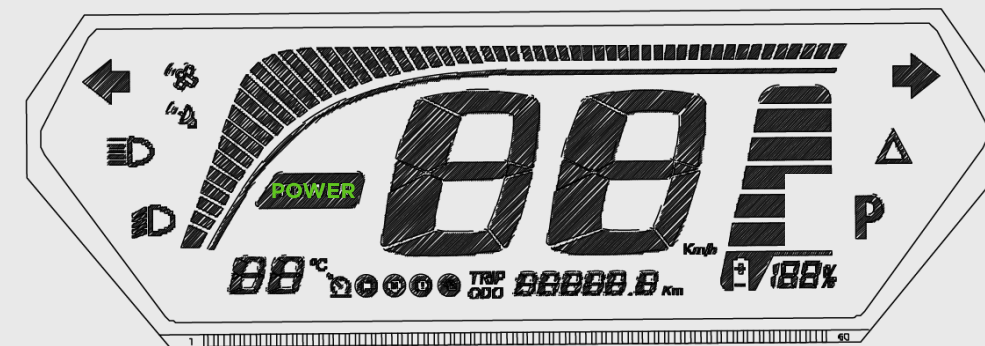

P mode (Power)

o start the electric scooter press the P button once and the P will disappear from the display. After that by default the POWER mode is predetermined.

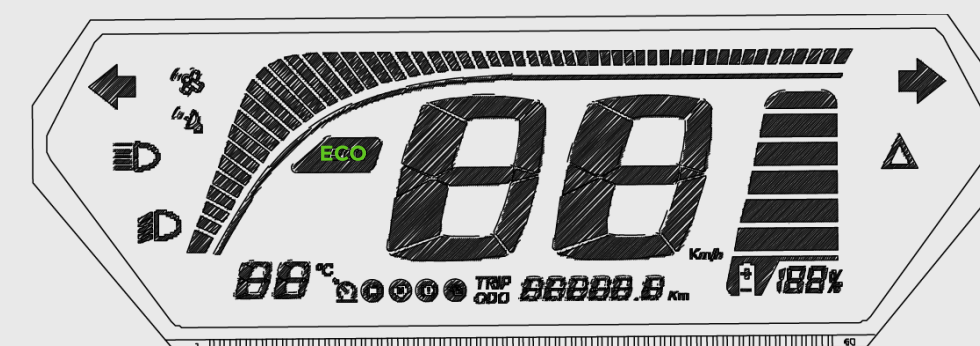

Mode E (ECO)

In the E mode the vehicle will gradually accelerate with more controlled power, to optimize the battery.

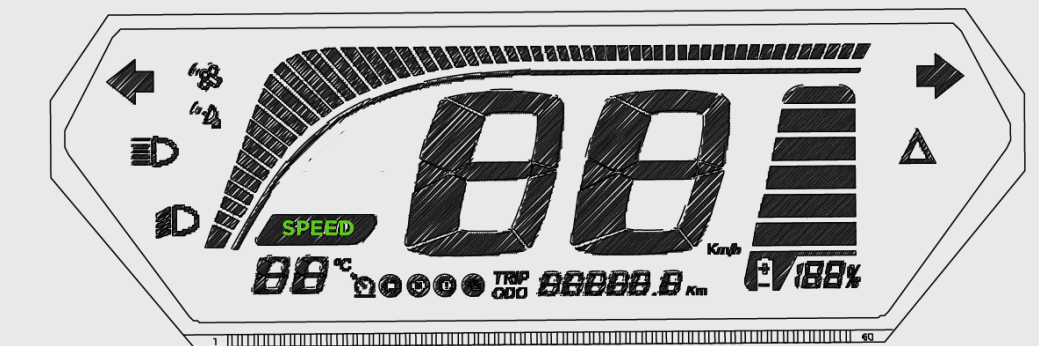

S mode (Speed)

In mode S, is the riding mode that will supply your vehicle with the most power.



Display/ Speedometer

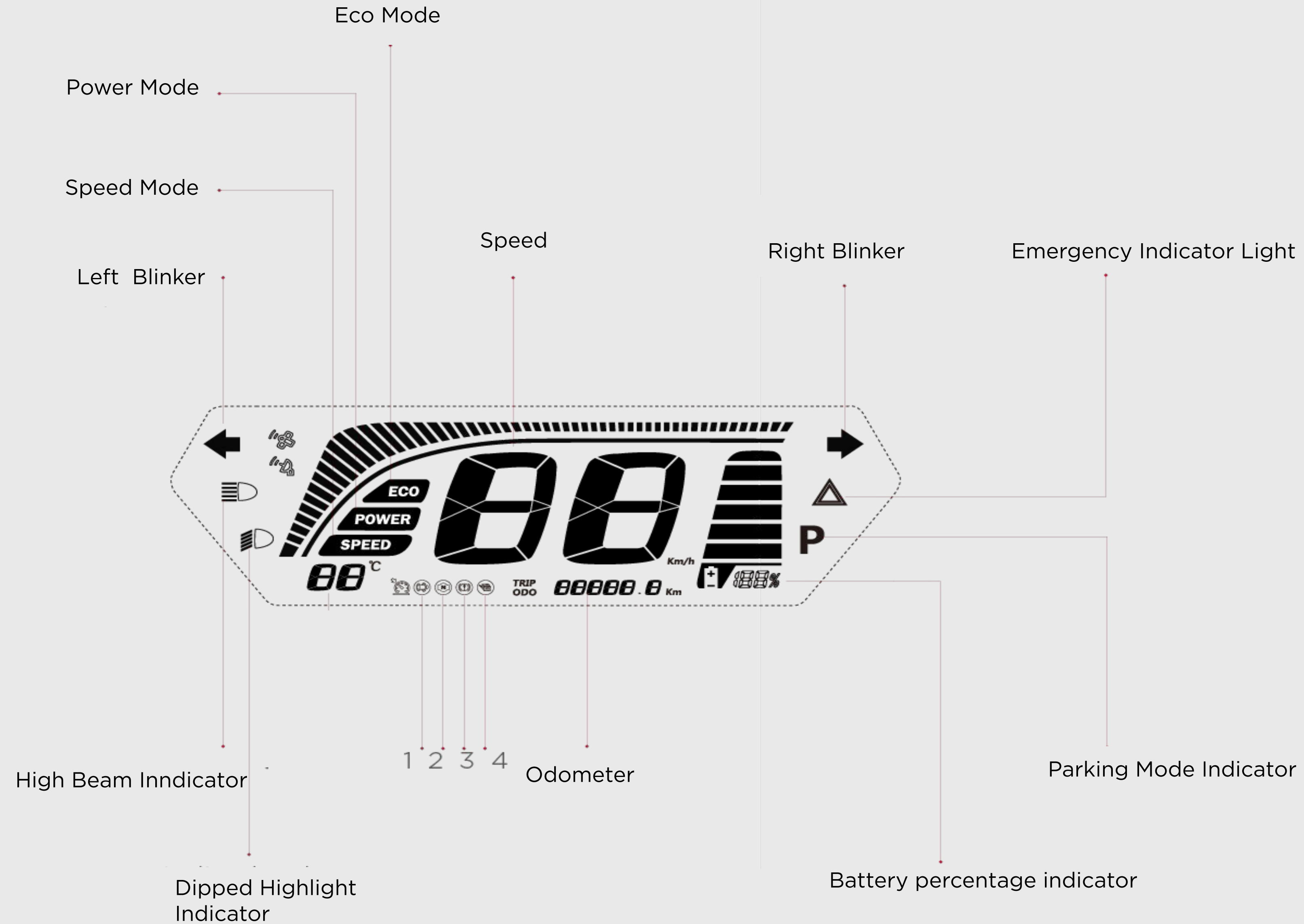



Instructions of use

We begin with just one button Lock

To turn on the NX1 the mechanical lock method can be used or the button can be pressed

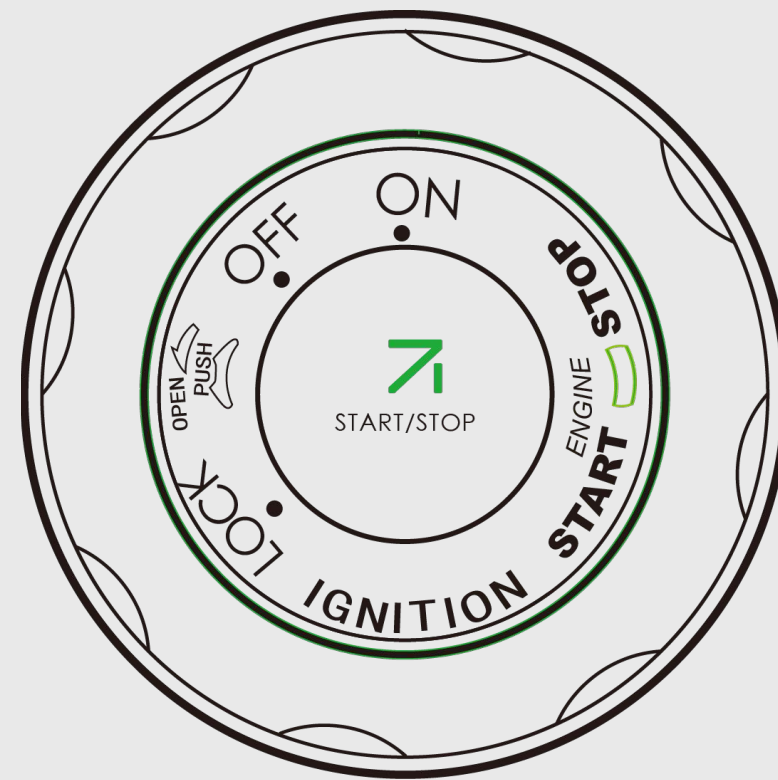

Remember that the **MASTER** option is the remote control to turn it on, turn off/to turn the alarm on, unlock and look for the vehicle. The ignition key can only be used mechanically: lock the steering and open the seat.

Cerradura

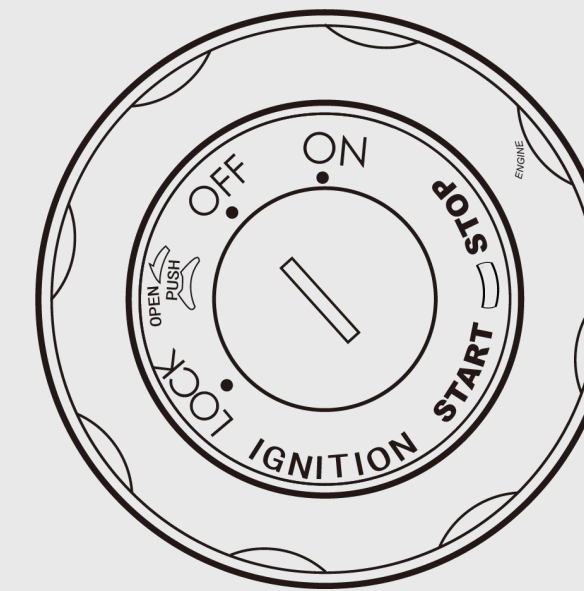

Position OFF

The vehicle is off.

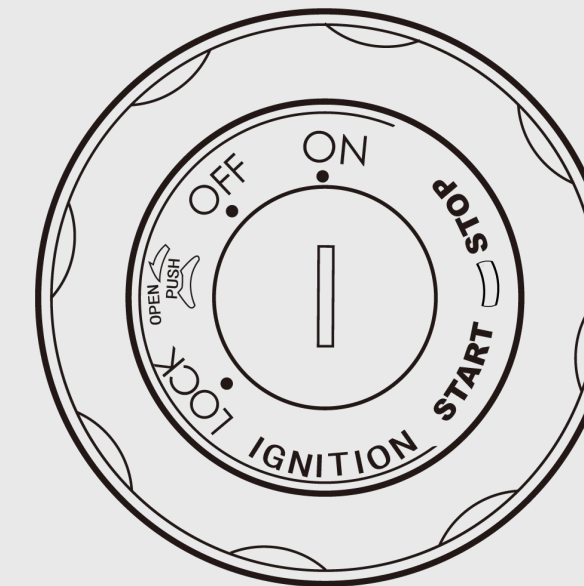

Position ON

The vehicle will turn on.

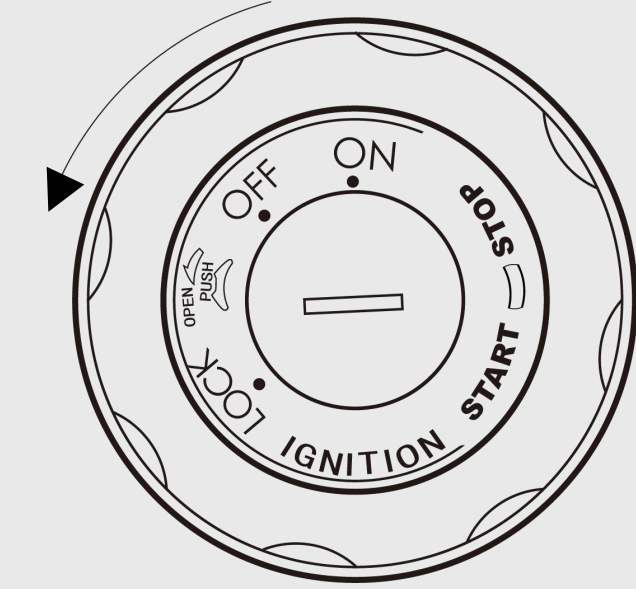

OPEN Mode

Turn to the left in the OFF position to open the seat.

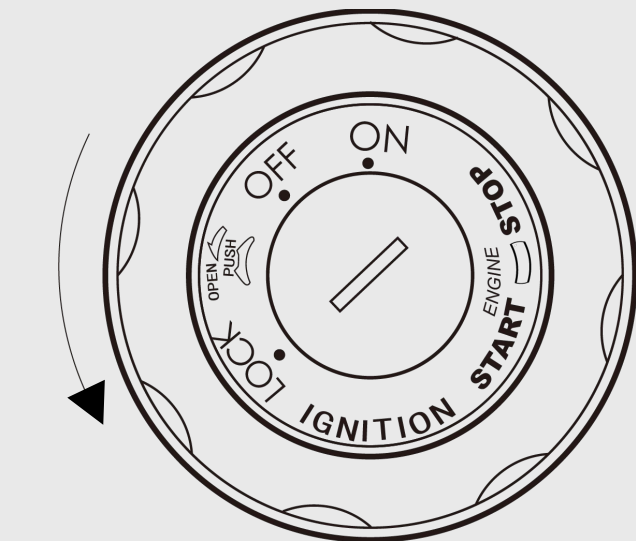

Position LOCK

Turn anticlockwise, from the OFF position (by inserting the ignition key all the way) to LOCK to lock the steering.



Instructions of use

Remote Control

Initial Reference State: To begin learning the operation of the remote, we will start with the reference state "vehicle off."

- 1. Vehicle Off State:** The circuit breaker (under the seat switch) must be ON.
 - To turn off the motorcycle, press the off/alarm button ("closed padlock") or put it to sleep (press the unlock button "open padlock" + wait 15-30 sec). If the ignition LED is off and the display is also off, it means the motorcycle is off.
 - Press the "open padlock" button and then the "closed padlock" button to switch to the "vehicle off" state. In this state, the alarm will be active, and any vibration or improper use will trigger it.
 - 2. Vehicle On State:** The LED on the ignition will be flashing.
 - To turn on the vehicle, press the power button twice.
 - Press the "open padlock" button and then the "closed padlock" button to switch to the "vehicle off" state. In this state, the alarm will be active, and any vibration or improper use will trigger it.
 - 3. Vehicle Unlocked or Sleep State:** The LED on the ignition will be flashing.
 - To turn on the vehicle, press the logo button twice.
 - Press the open padlock button to turn off the display and activate the ignition LED. If it hasn't been more than 15-30 sec., you can move the motorcycle without triggering the alarm.
 - Press the open padlock button for 15-30 sec. to activate the "sleep state," and when it detects any movement, the display will turn on, and the rear wheel will lock. The alarm will not sound in any case.
- 3. Remote Seat Opening:** In any of the aforementioned states, the remote seat opening is performed by:
- Pressing the open padlock for 3 sec., and the seat will open.

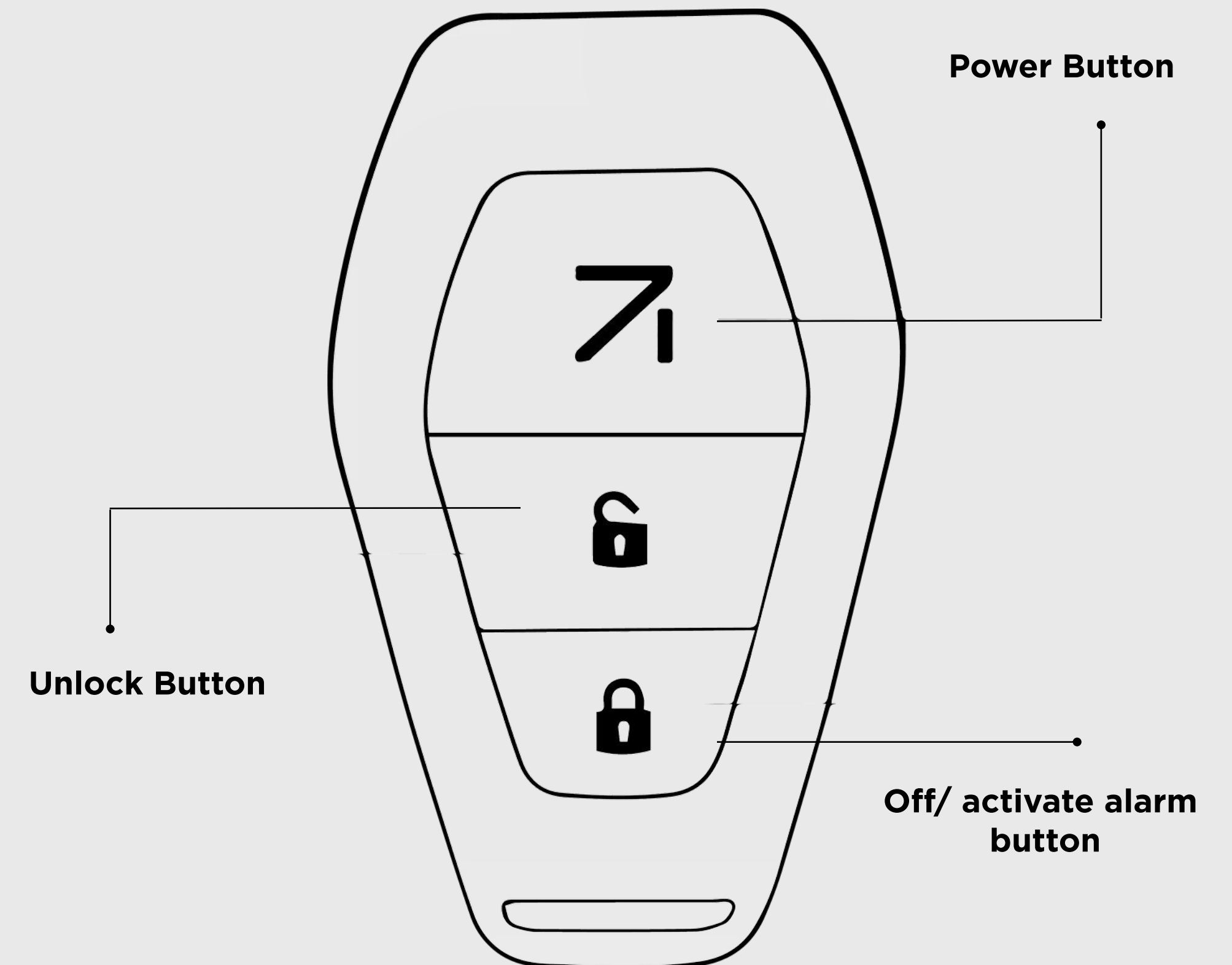



Instructions of use

Quick Installation

1. Rear View Mirror

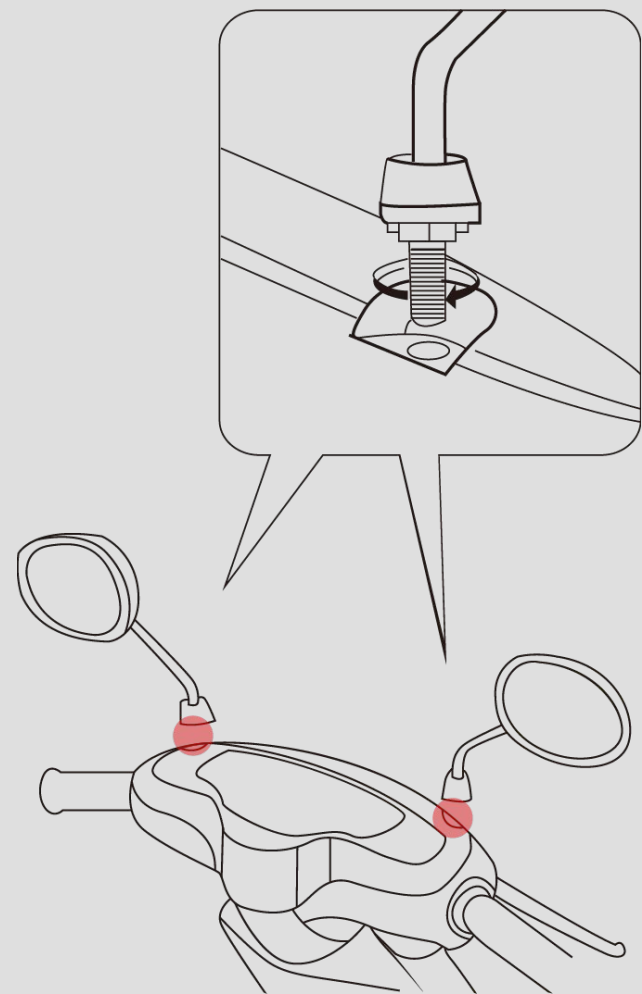

2. Number Plate

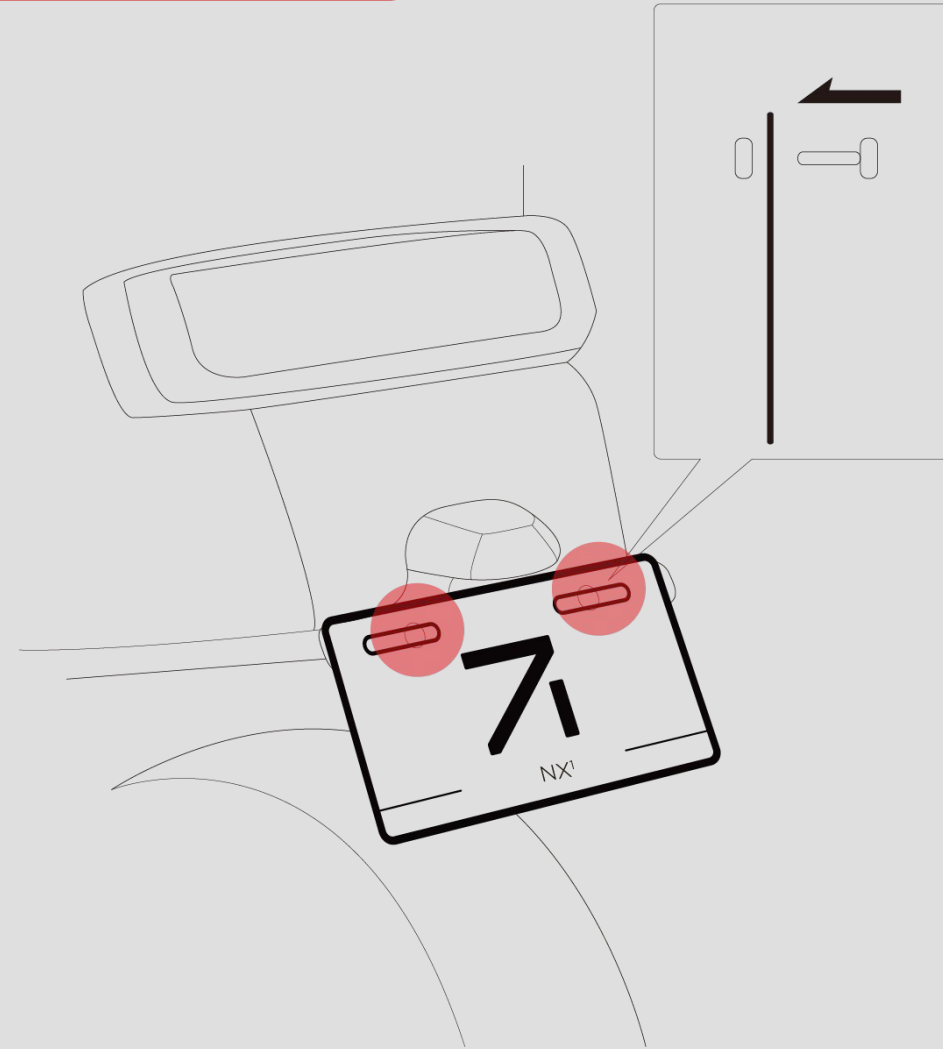

3. Backrest

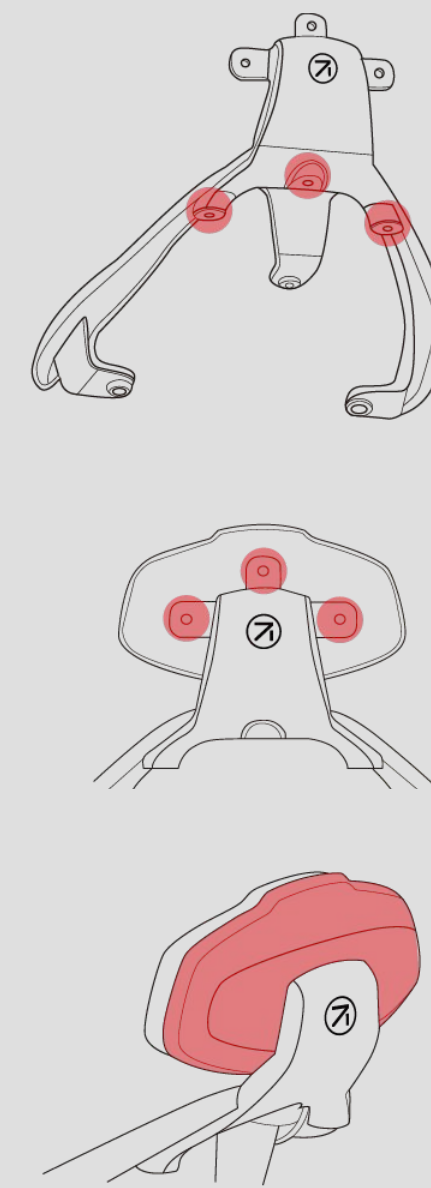

4. Top Box

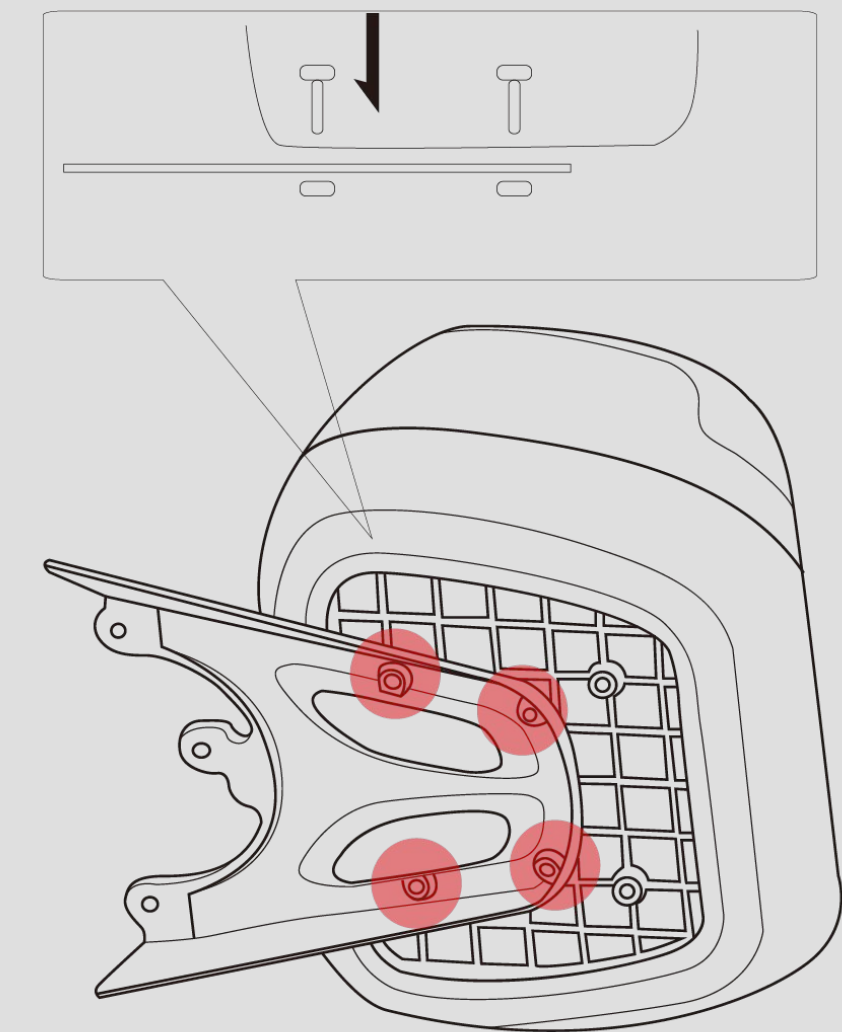

REMEMBER: The top box is optional and it does not come with the basic equipment.



Battery

Location of the batteries

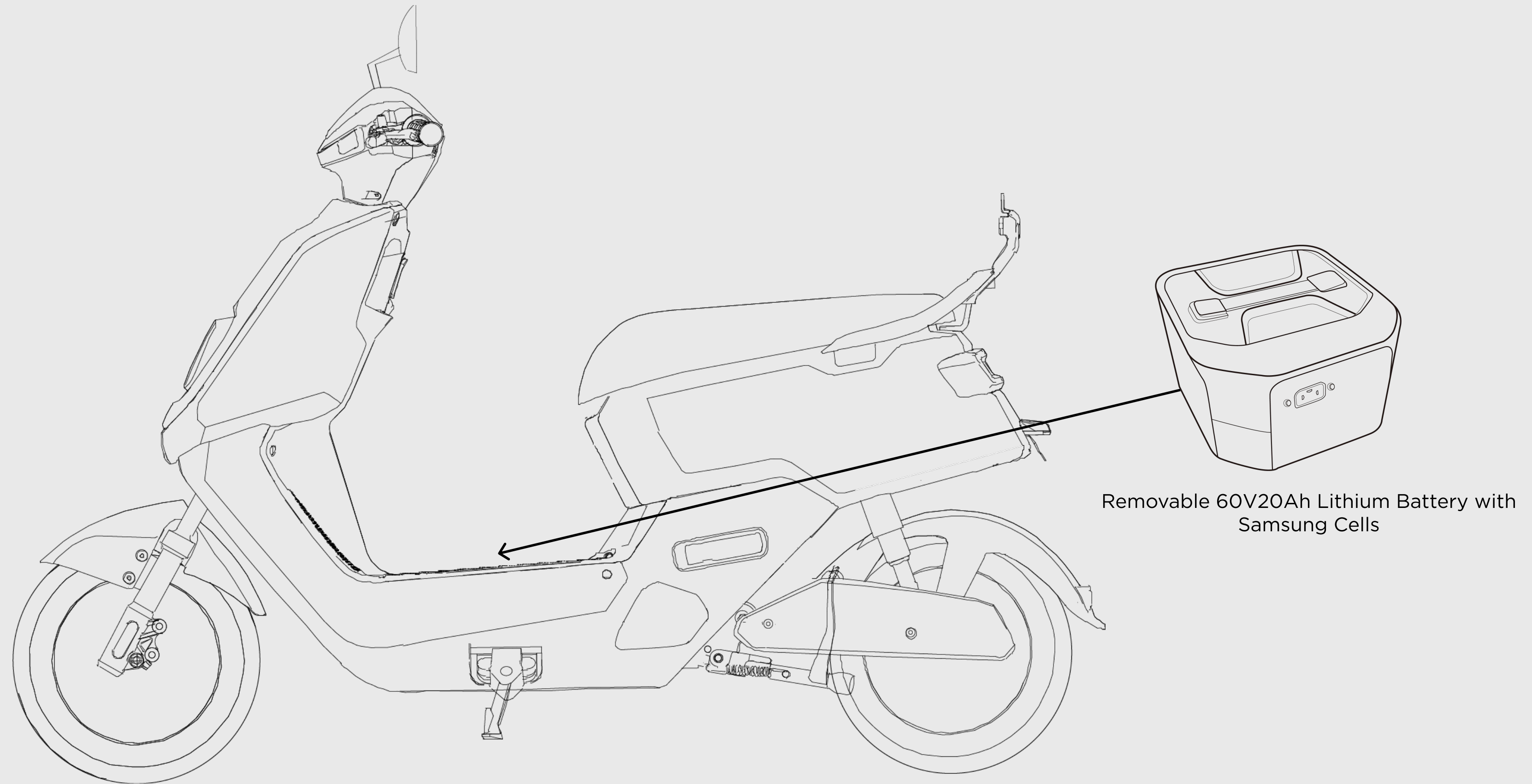

Removable 60V20Ah Lithium Battery with Samsung Cells



Remember that this vehicle uses lithium batteries because they are light, compact, they have a long lifespan and they are easy to remove and charge. The batteries have to be charged using the external charger that comes with the vehicle, keep it out of reach of children. REMEMBER that the batteries and the charger have high voltage areas that might be dangerous and hazardous for your health.



Battery Specifications

Batteries	Removable 60V20Ah
Weight	9kg
Management	FOC System
Charging Time	6 hours
Battery Range	65 kms

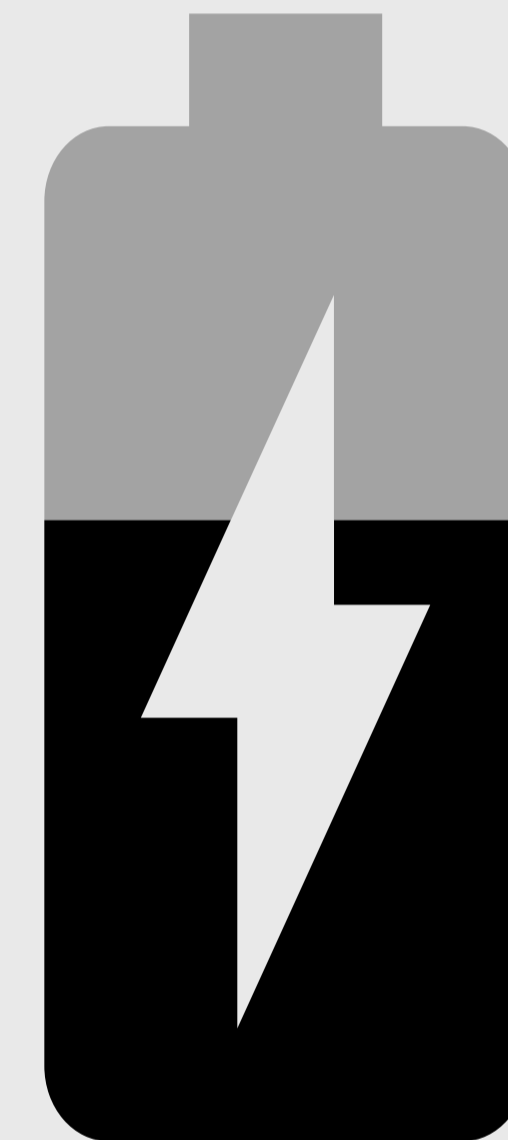



Charging battery

Read the charging instructions carefully. **There are two charging options:**

1. DIRECT CHARGING PORT ON THE VEHICLE

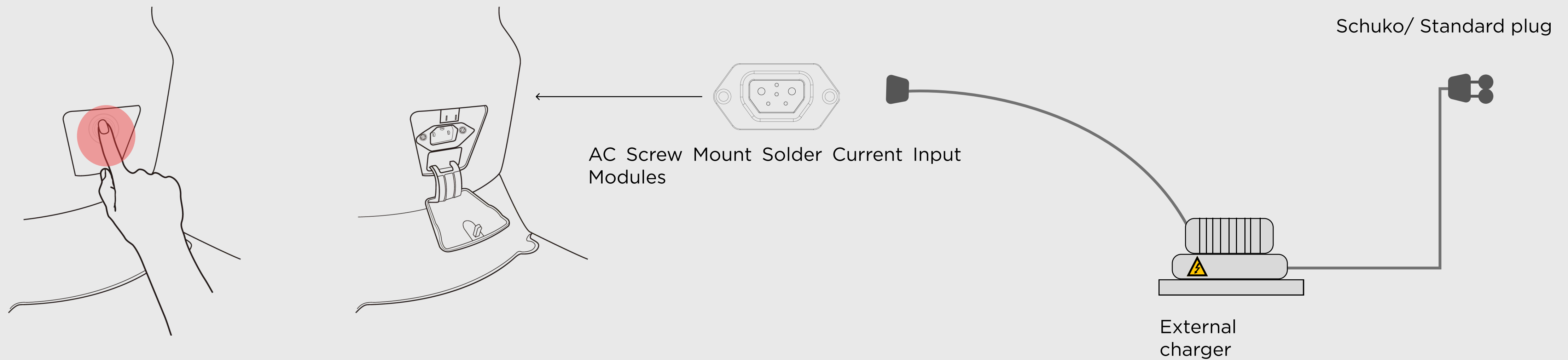

↳ Gently press the top part of the cover, where the connector is located, to access the charging socket. Take the charger, plug it in, a light will go on when it is fully charged



Charging battery

Read the charging instructions carefully. **There are two charging options:**

2. REMOVABLE BATTERY

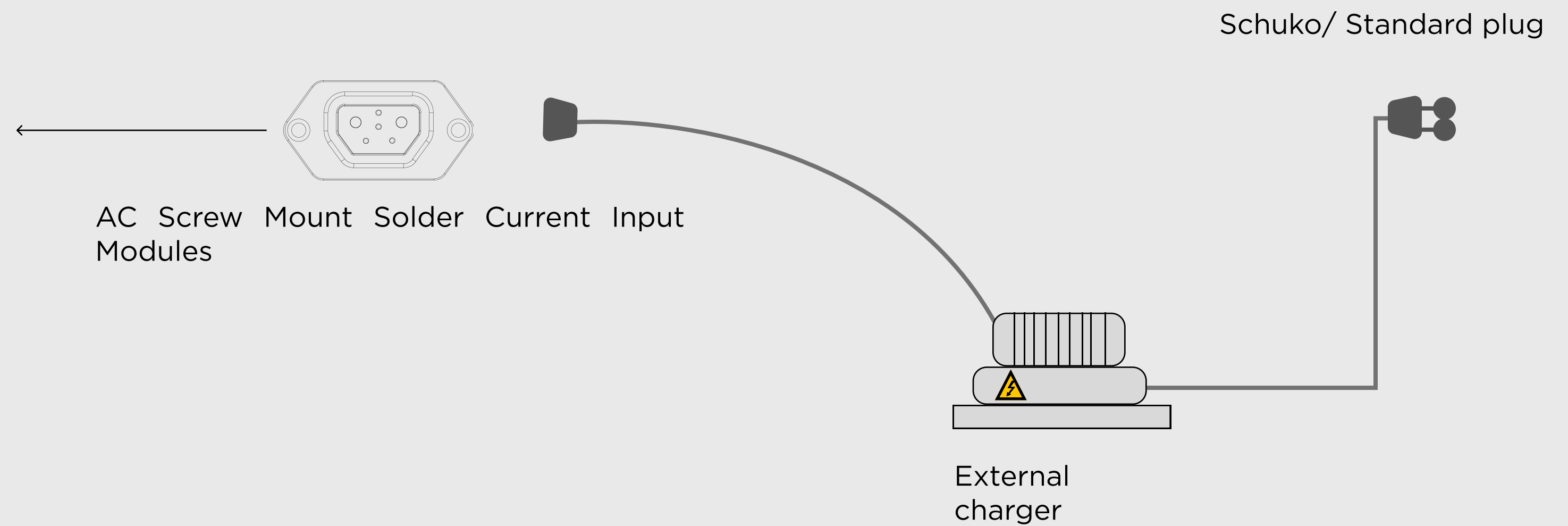
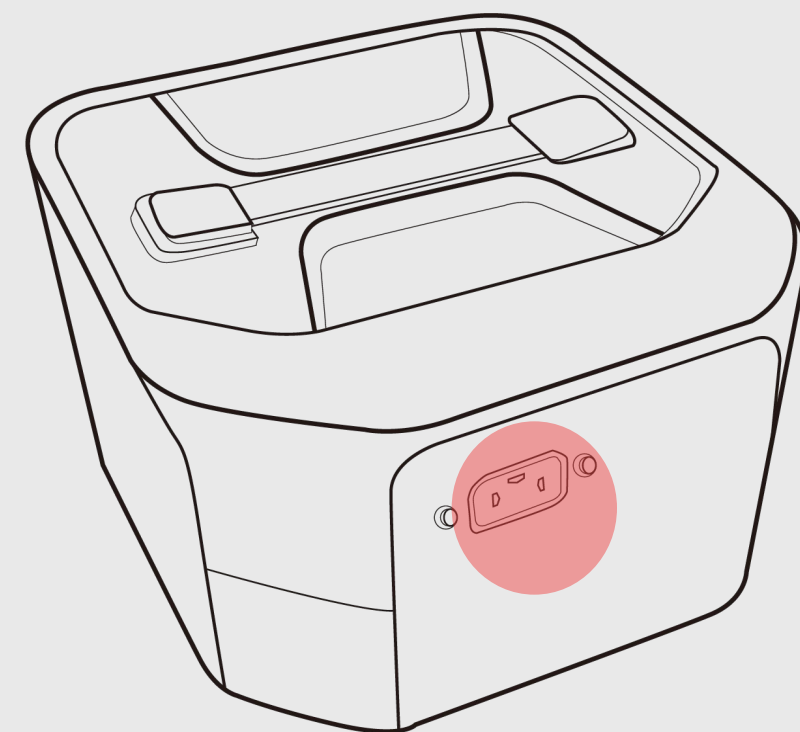

First open the top box, then unlock it using the key to access the battery compartment. The lithium battery can be removed to charge it in the most convenient place. Please, use the original NEXT charger for lithium batteries, and there is a light on the charger that shows the charging status



Battery maintenance

1. Charge the vehicle when the ambient temperature is between 0°C and 45°C.
2. Put the vehicle somewhere safe, out of the reach of children, while it is charging.
3. To avoid affecting the lifespan of the battery, do not charge it for more than 12 hours at a time.
4. If the battery is not fully charged after 12 hours, stop charging it.
5. To guarantee that the battery lasts a long time and optimum performance, always keep the battery charge level between 20% and 90% when riding the electric scooter.
6. If you are not going to use the vehicle for a long time, store it in a place where the temperature is between 0°C and 30°C, and make sure that battery is at least 50% charged.
7. Completely charge and use up the battery at least once a month; to prevent an irreversible battery capacity loss.
8. Do not charge the vehicle in the rain or anywhere that is wet or damp.
9. Do not expose the battery to temperatures of between 0°C and -25°C or environments with an ambient humidity of less or equal to 65% RH.



10. The battery capacity decreases 1% with each 1°C drop in the temperature.
11. During the winter, when it is colder, the battery cycle capacity is weaker, and the electrolyte viscosity increases. This increases the resistance of the chemical reaction, which can shorten charging time (up to 70% if the vehicle is charged when it is below 5°C).
12. The charging capacity decreases to between 60% and 70%, while the discharging capacity is affected by between 50% and 60%. This, in turn, will decrease the battery range of the vehicle.
13. The battery must not be charged when the ambient temperature is below 0°C.
14. The charge power rating is 0,24 kW.



Vehicle maintenance

Frequency of services

The correct maintenance and use of the vehicle can increase its lifespan considerably. If the vehicle is not going to be used for a long time please check it on a regular basis.

The first service should be done at the end of the first month or after the first **1000kms** of use.

After that, the general condition of the vehicle should be checked every **5000kms**.



These reviews only apply to models obtained from 2024 onwards, and to earlier models with conversion. Otherwise, the reviews will be applied as indicated in the manuals of previous versions.



Warranty period

NEXT Electric Motors guarantees that this product is free of material defects and in normal conditions of use. It also guarantees the labour involved in servicing it for a 3 year period or for 20,000 Km as of the original purchase date.

Warranty coverage

During the warranty period, NEXT Electric Motors pledges to repair or replace, at its discretion, any part or product that is deemed to be faulty due to defective materials or inadequate workmanship. The warranty does not cover damage caused by misuse, accidents, unauthorised modifications, incorrect installation, natural disasters or other events that are beyond the control of NEXT Electric Motors.

Warranty claims process

Warranty claims process- To make a claim on this warranty, customers should get in touch with our customer service or the distributor where the vehicle was purchased using the contact details supplied in each case. The following information should also be provided:

- Model and VIN.
- Proof of purchase (original receipt).
- Detailed description of the problem.
- Details about it passing all the inspections and services.

 This warranty covers any damage done to the vehicle and its corresponding battery. This warranty is governed by Spanish law and any dispute related to this warranty that arises shall be submitted to the competent courts in Spain.



Warranty exclusion

1. Exceeding the vehicle's maintenance periods.
2. Damage caused by improper use, such as collision, fall, overload, overspeeding, and failures caused by not driving according to the instructions for operating the electric vehicle.
3. Damage to the paint finish resulting from participation in competitions and/or training for such activities or events or as a result of exposure or use of NEXT Electric Motors vehicles in extreme conditions or weather.
4. Damage caused by smoke, drugs, chemicals, salt, rust, discoloration, or natural deterioration and failures caused by force majeure such as earthquakes, typhoons, floods, fires, etc.
5. Phenomena that do not significantly affect normal driving sensation or performance, such as vehicle collision, noise, etc.
6. Unauthorized disassembly or damage to vehicle components caused by it.
7. Damage to the charger, battery, and motor due to non-compliance with usage instructions.
8. Unauthorized use of non-original vehicle accessories and damage to components caused by them.
9. Changes to the "Product Warranty" certificate or the product model and chassis and/or engine number do not match the "Product Warranty" certificate.
10. Damage to components due to human factors.
11. Using the charger on a vehicle of another brand without permission.



Information about returns

Our priority at NEXT Electric Motors is to guarantee the satisfaction of our customers. However, given the nature of our products and the electric scooter registration process, returns shall only be accepted if the vehicle has not been registered yet and within the first 15 days as of the purchase date.

Return conditions

- The electric scooter must not have been registered.
- The request to return the vehicle must be made within the first 15 days as of the date of purchase.
- The electric scooter and all its accessories must be like new, without any signs of use or damage.
- Customers must provide the original receipt of purchase.

Exceptions

No returns shall be accepted after the first 15 days after the purchase date or if the electric scooter has already been registered. Furthermore, returns of damaged or misused products, those that have been in accidents or modified without authorisation shall not be accepted.



Recommendations

1. Acquire good charging habits. Make sure that the vehicle has more than enough battery range before using it.
2. The battery is an important part of the vehicle and it is affected by various external factors. In general terms, the discharge performance of the battery is good at high temperatures. However the battery capacity might decrease by more than 1/3 if the temperature drops below 0 °C. So, in the winter, it is quite normal that the battery range decreases after it has been charged. When the temperature rises above 25°C, it will work as normal.
3. A charger that is not designed for the vehicle (or that has not been supplied by NEXT) must not be used to charge it. NEXT shall not be held responsible for any accidents or defects in the vehicle caused by this.
4. When going downhill, make sure that you use both brakes to stay stable and avoid any accidental injuries that might be caused by the forward movement of the centre of mass.
5. Before using the vehicle, make sure that the brakes, the shock absorbers, the chassis, the handlebars and the tyres are safe and are in good condition to prevent any accidents.
6. Avoid riding on muddy or bumps roads or steps to avoid any accidental punctures, deformation of the wheels or damage to your electric vehicle.
7. Do not hang heavy objects from the handlebars, because this might affect the steering.
8. It is strictly prohibited to short circuit the positive and negative terminals of the battery with wires or electrical conductors, to avoid hazards and damage to the battery.
9. Handle the battery with care to avoid damaging it or banging it.

Technical Specifications

PERFORMANCE & BREAKS

Max. Speed	45 Km/h	Power Modes	Eco/ Power/ Speed	Front Break	Disc
0-50 Km/h	4,5"	Rated Power	0,8 Kw	Rear Break	Disc
Max. Range	65 Km Standard 130 Km Powerpack	Peak Power	1,7 Kw	Disk Dim	Front 260mm/Rear 180mm
Max. Torque	25 Nm	Motor Manufacturer	Brushless Next Electric Motors	Braking System	Standar

DIMENSIONS

Weight (M.R.O)	56 Kg	Dimensions	1680*675*1060	Ground Clearance	Yes	Tire Brand/Type Front	2.75 R10 80/90 R10/ Michelin- Chao Yang
Max. Load	215 Kg	Seat Height	720 Mm	Wheelbase	1270 mm	Tire Bran/ Type Rear	2.75 R10 80/90 R10/ Michelin- Chao Yang

Technicals Specifications

BATTERY					
Power	72V 25 Ah *2	Additional Battery	Yes	Charging Power	60Vx4A(0.240 KW)
Battery Type	Lithium-Ion	Charging Time	4h	Cycle Range (kM) WLTP	65 Km X 1 Batt
Removable Battery	Yes	Charging Cycles	600	Cycle Range (km) Eco/ Drive	100 Km X 1 Batt
Included Battery	1	Battery Manufacturer	Samsung		
OTHER SPECS					
Under Seat Truck	No	Glove Compartment	No	Max. Passengers	2
Does A Helmet Fits Under The Seat?	/	Accessories	Top Case	Mobile App	No
				Transmission	No

Technicals Specifications

WARRANTY

Vehicles Warranty 3 Years/20.000 Km

Battery Warranty 3 Years/20.000 Km

INSPECTIONS

1st Inspection 1.000 Km

Rest Each 5.000 Km



Warranty registration

The following registration form has to be filled in and signed by the authorised centre so that you can use the warranty.

Date/ Km	Centre	Comments



Warranty registration

The following registration form has to be filled in and signed by the authorised centre so that you can use the warranty.

Date/ Km	Centre	Comments



N E X T M O T O R S

